

Wheel cabinet

PASSENGER SIDE



Installation manual

General information

IMPORTANT Always make sure all connections are tight and secure before driving and occasionally check the fittings in particular when going off-road.





TIP Clean the powder coated surfaces by using a mild soap, try to avoid any aggressive detergents.

NOTICE The installation can involve working with electricity, water or gas. Please make sure you are competent or contact a professional.

FITS





REICH water tank 90L
VECAM water tank 90L

Required tools

-  | 4mm
-  | T15 + T20
-  | Drilling machine
-  | Rivet tool

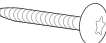

BOLT KIT

Wheel well cabinet

-  **8x** 5x12mm
-  **4x** M5x16mm
-  **4x** M5 cap black
-  **4x** M6 rivet
-  **4x** M6x16 flange bolt
-  **6x** 5x20mm

BOLT KIT

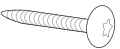
Water tank/pump bracket

-  **4x** 5x12mm
-  **10x** 5x20mm
-  **10x** M5x16mm
-  **10x** M5 cap black

General information

Options

1

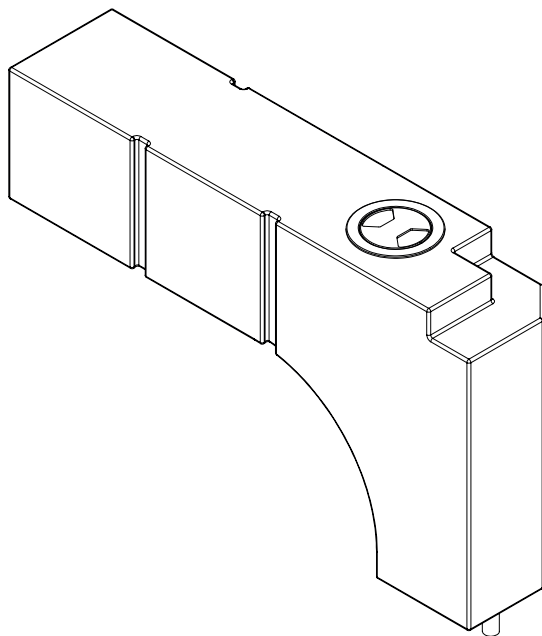

2x

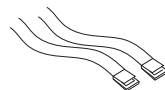
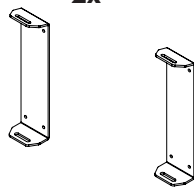

Wheel water tank

REICH water tank 90L
VECAM water tank 90L

2

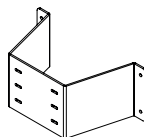
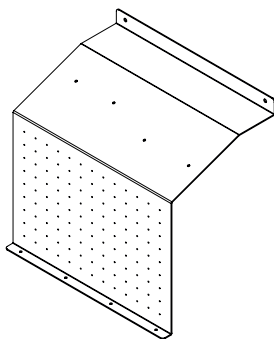

**Pump bracket
A/B**

Placement

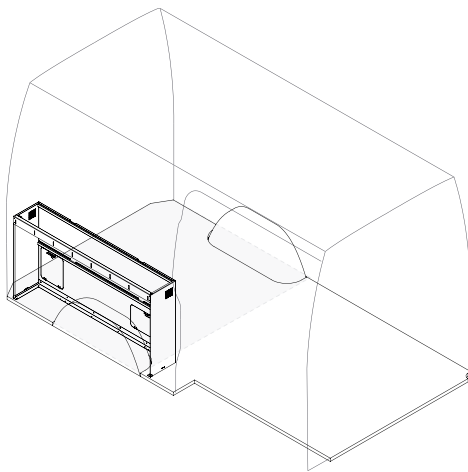

figure 1

MB Sprinter **L2** (2006+) / VW Crafter **L2** (2006-2018) | VW Crafter/MAN GTE **L3** (2018+)

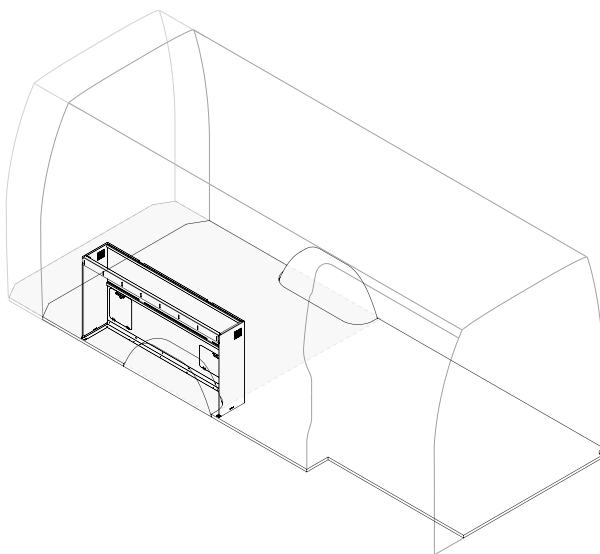
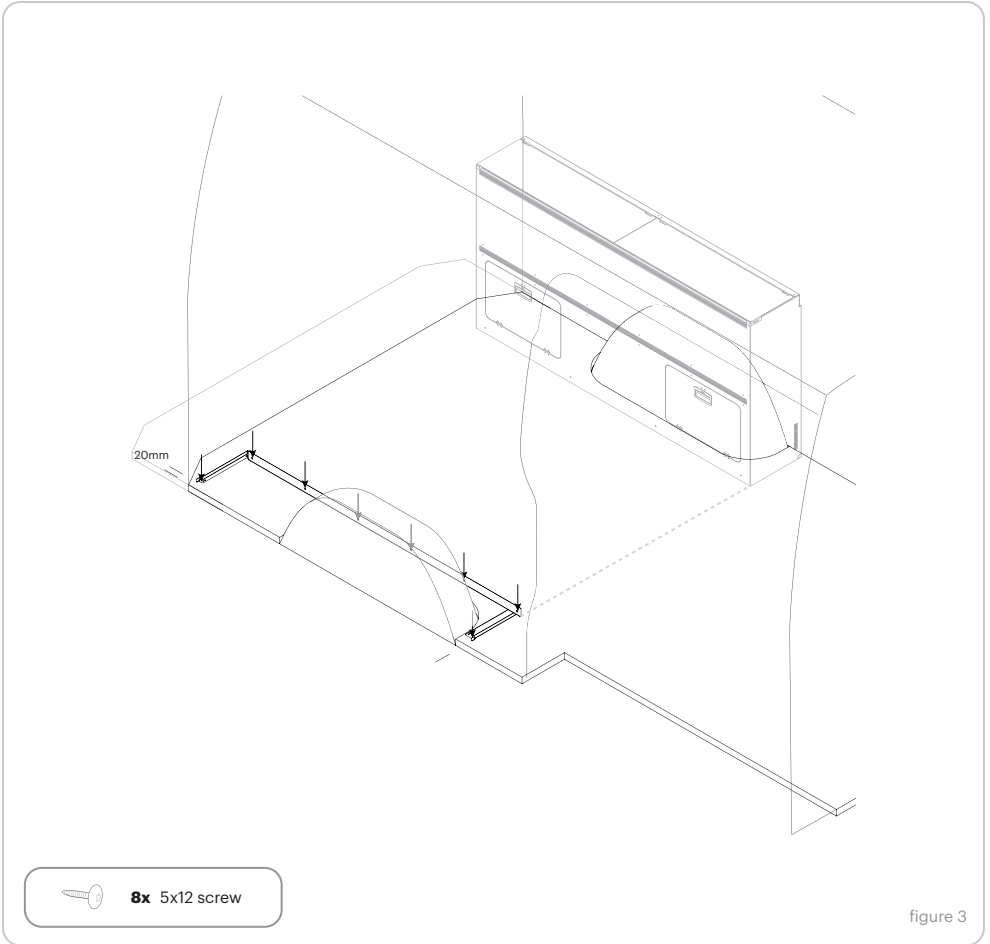

figure 2

MB Sprinter **L3/L4** (2006+) / VW Crafter **L3/L4** (2006-2018) | VW Crafter/MAN GTE **L4** (2018+)

Installation

Infrastructure



1. Place the floor bracket over the wheel well on the passenger side. Give it a 20mm offset from the wall. Align it to the opposite wheel well cabinet. You can check this by using any measurement on the original flooring or by the distance relative to the wheel well.

Installation A

Pump bracket option A Sprinter RWD / AWD

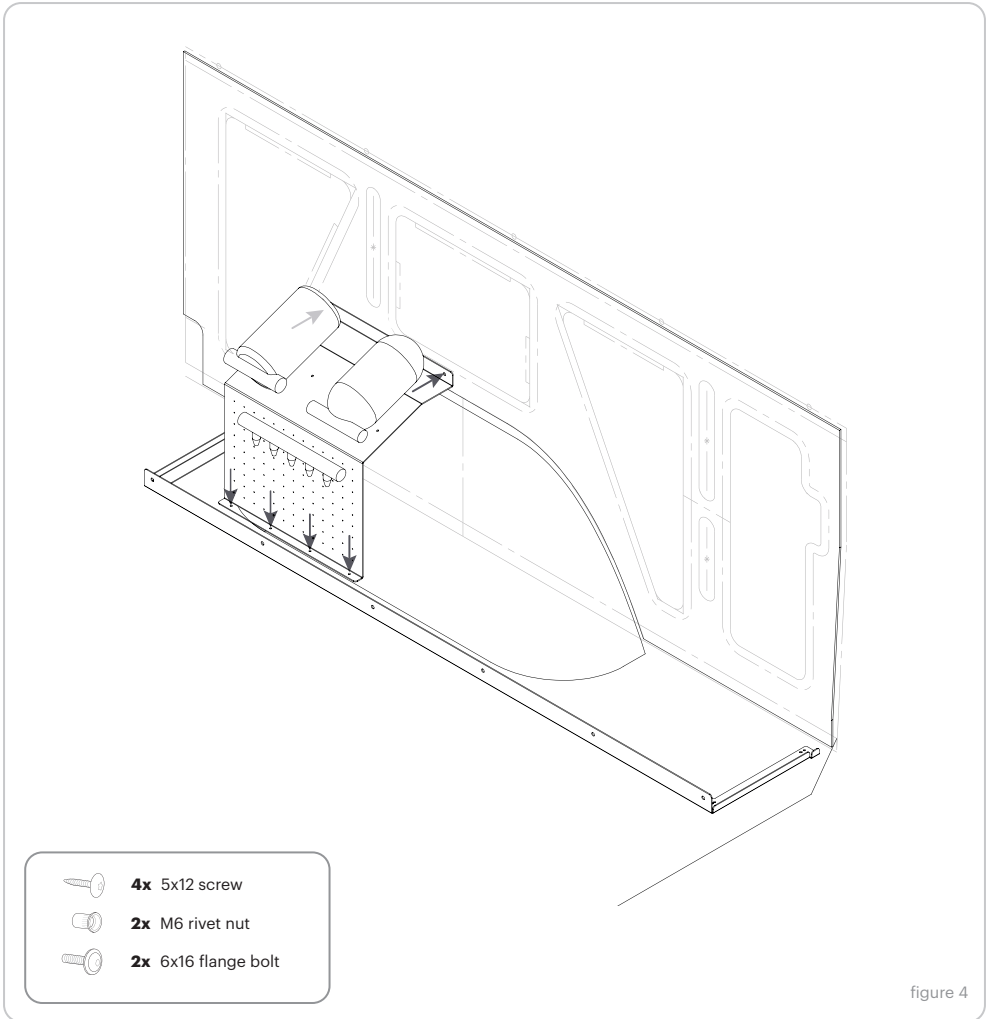

2. The pump bracket for option A should be positioned on top of the wheel well and can be connected directly to the chassis via the M6 rivets. Now screw into the floor by the 4 screws.

Installation B

Pump bracket Sprinter FWD / Crafter MAN AWD

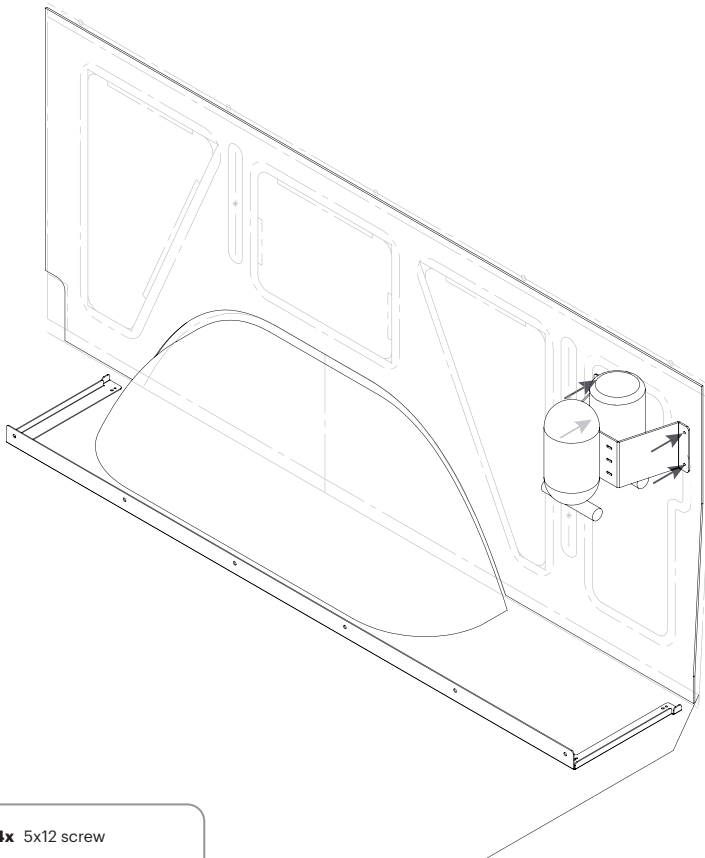

4x 5x12 screw



4x M6 rivet nut



4x 6x16 flange bolt

figure 5

2. The pump bracket for option B can be positioned on the right side, ideally connecting directly to the chassis or via a bracket or firm panel (9mm+). Use either the included rivets and bolts or screws.

Installation

Water tank brackets

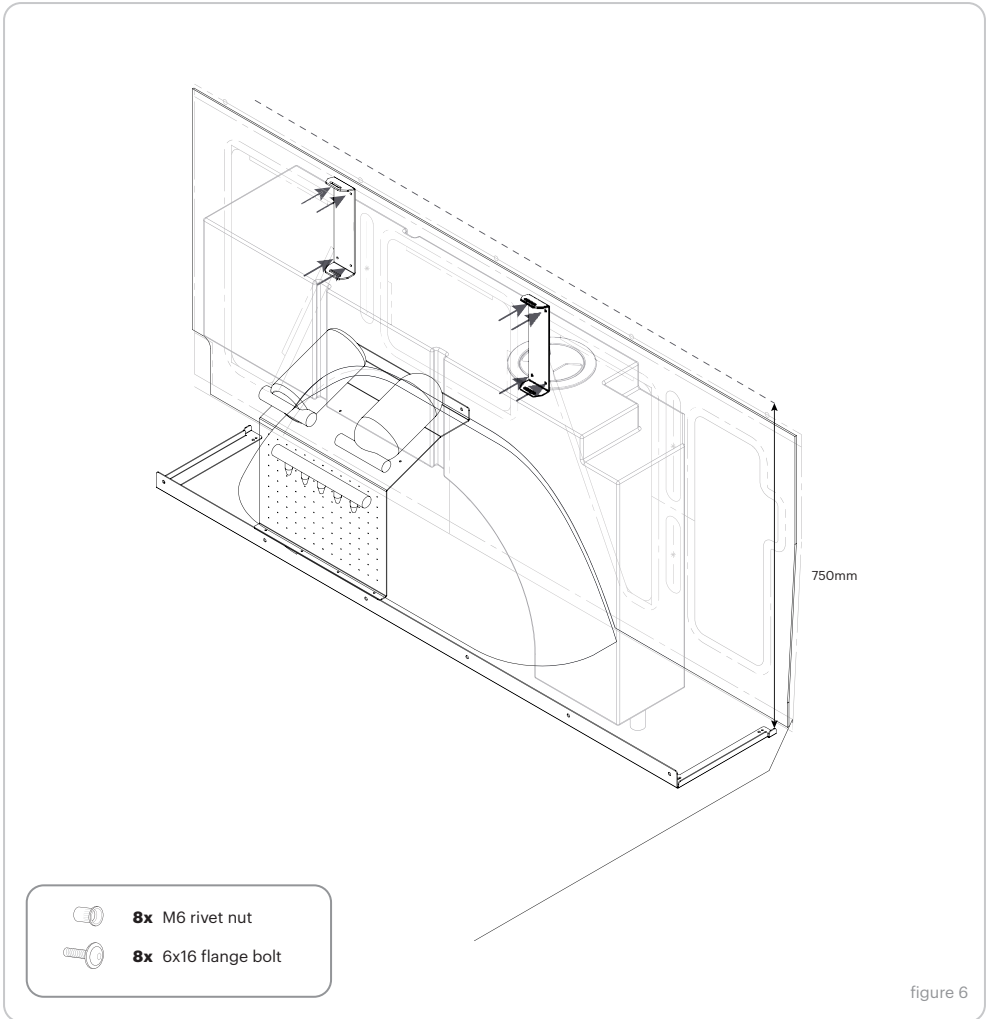

3. The water tank will be connected directly to the chassis via the brackets. To determine the exact location we recommend to pre mount it. It might be necessary to raise the water tank in order to prevent interference with any of the pumps (brand dependent).

Note The final position of the water tank might be lower when it will be filled with water

Installation

Water tank

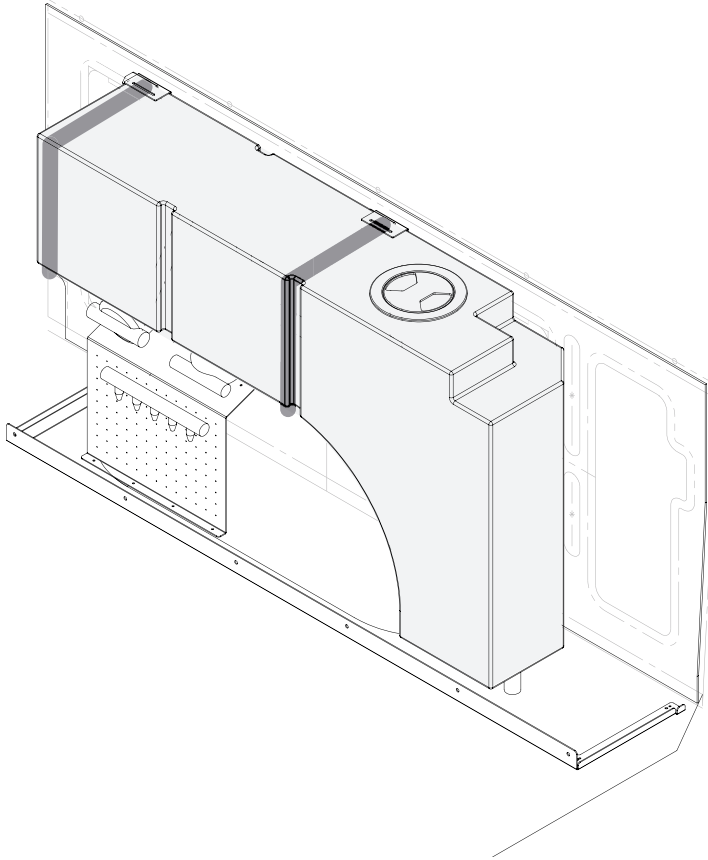
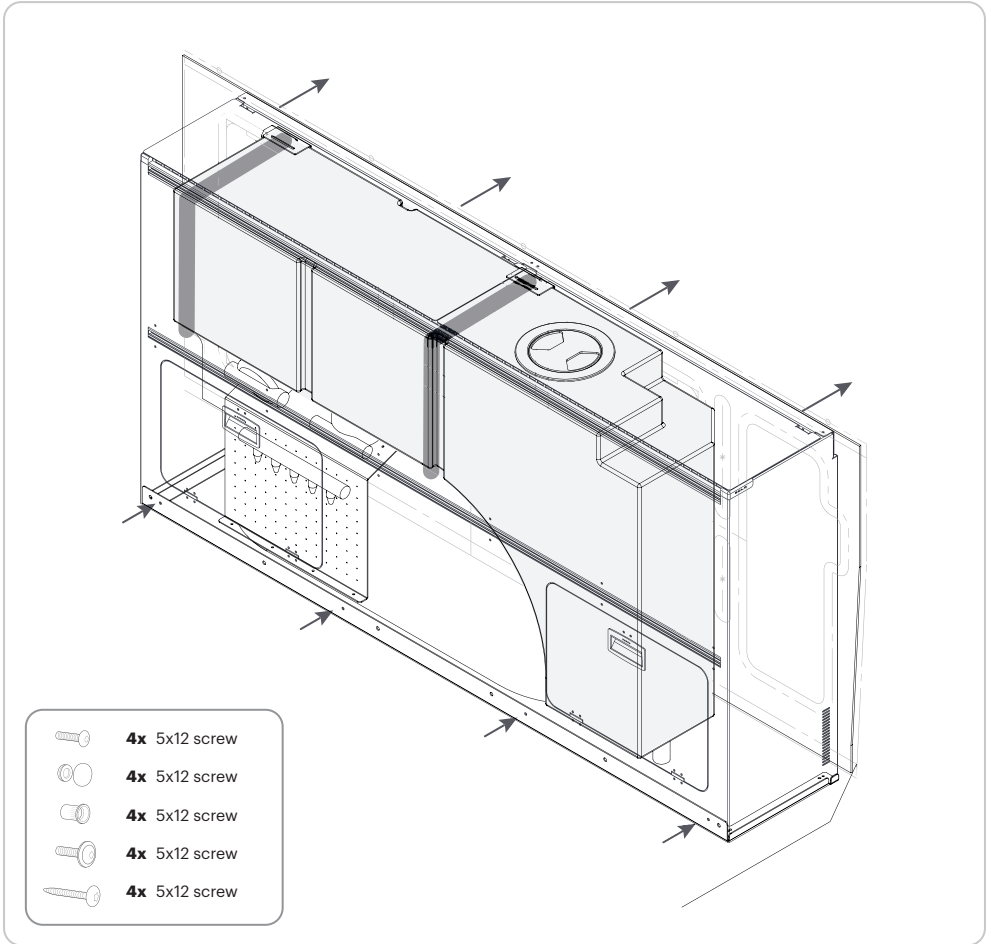

figure 7

4. Firmly strap the water tank to the brackets. The straps are rated for 250kg each. However we recommend to make a safety knot in case of the the unlikely event of failure.

Installation

Wall attachment



5. Close off the water installation by placing the cabinet over the bottom bracket. Use the M5 bolts and the black caps to connect them together. Fixate the back from the inside of the cabinet by either the included rivets, screws or directly the OEM cargo rail.

Note: The wheel cabinet functions as a cover and is designed to be taken off easily in case of any maintenance, malfunctions or upgrades

Installation

Cargo bay



6. The cabinets are designed to create a large cargo area where a lot of storage configurations are possible. Thanks to the slim proportions it will be possible to place 3 EURO size boxes of 400mm

